



PLC Stamp mini 2 Datasheet

in-tech smart charging GmbH

Sep 24, 2020



Contents

1	Revisions	3
2	Used Symbols	3
3	Abstract	4
4	Applications	4
5	Interfaces	4
6	Handling	5
7	Module Overview	5
8	Technical Data	6
8.1	Absolute Maximum Ratings	6
8.2	Operating Conditions	6
8.3	Safety	6
9	Firmware and MAC Addresses	6
10	Module Pinout	7
10.1	GPIO	8
10.2	Serial Signals	9
11	Recommended Footprint	10
12	Getting Started	11
12.1	CE Class B / North American Variant	11
12.2	Automotive EVSE / PEV	11
13	Processing	12
14	Module Marking	12
15	Order Information	13
16	Package Materials Information	21
16.1	Tape and Reel	21
16.2	Tape and Reel Cardboard Box Dimensions	23
17	Contact	23

1 Revisions

Revisions	Release Date	Change
12	September 24, 2020	add section Used symbols
		automotive variants for versions -002 and -003 deleted from the order code table
		add warning and notice to section 12.2
11	May 5, 2020	added version -003 and -004 to order codes table
		fixed broken reference in chapter "Getting Started", added 'Motorola' to SPI mode description
		update example module label
		added table with QCA firmware versions
10	October 26, 2017	corrected QCA7005 order codes (some incorrectly had order code I2PLCAMN-... instead of I2PLCBMN-...)
9	September 5, 2017	added section "processing"
8	June 13, 2017	updated section "GPIO", corrected error in meaning of GPIO levels
7	February 1, 2017	added Package Materials Information and order options, adding info about difference in QCA7000 and QCA7005
6	August 8, 2016	added safety related info: test voltage, creepage, clearance
5	March 21, 2016	added GPIO output current limit, add all GPIO3 functions and timings
4	February 24, 2016	fixing GPIO function assignment
3	February 9, 2016	clarifying UART settings
2	January 25, 2016	adding default UART settings
1	November 16, 2015	initial issue

2 Used Symbols

Symbol	Symbol name	Explanation
	Warning	Failure to follow safety instructions could result in serious injury to people
	Notice	Failure to follow instructions could result in damage to property
	ESD Susceptibility	indicates that an electrical or electronic device or assembly is susceptible to damage from an ESD event

3 Abstract

The PLC (PowerLine Communication) module gives your application access to powerline communication based on the HomePlug® Green PHY™ Chip QCA7000 / QCA7005. You can realize point-to-point and multi-point connections depending on your application. The data will be transmitted as Ethernet packets over the power line. This gives you the opportunity to use TCP/IP or whatever network protocols you wish to use.

This module includes the needed galvanic isolation between the power line and the secondary signals. You can freely design the power supply external to the module so that it perfectly meets the requirements for your application.

The QCA7000 / QCA7005 by Qualcomm Atheros ensures compatibility with many other commercial powerline devices.

The main difference between the QCA7000 and QCA7005 is the chip package. The QCA7000 has a traditional QFN package, whilst the QCA7005 has a modified QFN for better optical inspection that is intended for the use in automotive applications with highest requirements on quality. The default option for these modules is the QCA7000.

Parameter	Value
Power supply	3.3 V
Power consumption	0.5 W
Data rate	max.10 MBit/s
Reach	maximal 300 m over the Powerline
Temperature range	-40°C - 85°C (industrial) / 0°C - 70°C (commercial)
Outline dimension	43.5 mm x 22 mm x 6.5 mm
Weight	5.6 g
RoHS	PLC Stamp mini 2 is manufactured in compliance with RoHS

4 Applications

- interconnection of household appliances to the Smart Grid
- connection of smart meters to Smart Meter Gateways and/or LAN/WAN/WiFi
- connection of sensors
- connection of photovoltaic equipment
- connection of heating and air conditioning system
- coupling of machines and measurement devices
- forwarding of digital signals (remote I/O)
- coupling of RF cells for home automation

5 Interfaces

Powerline: 230 V AC, 110 V AC, DC, dead-wire 2-wire-connections

Serial interfaces: UART or SPI (order option)

6 Handling



This electronic component is sensitive to electrostatic discharge (ESD).

The module contains components with **moisture sensitivity level (MSL) 3**. Please handle them accordingly.

7 Module Overview

The block diagram in figure 1 shows module components in the gray box as well as the connections and external components that you need in addition.

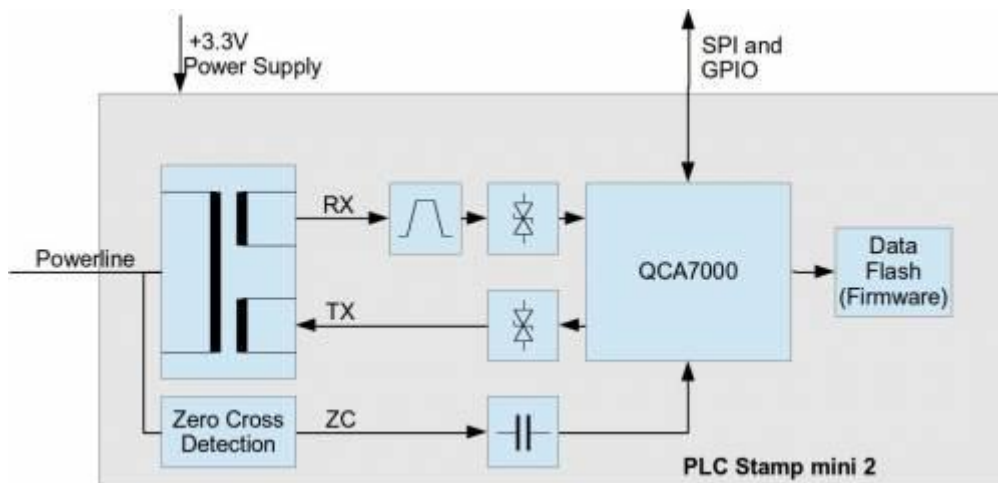

Figure 1 Block Diagram of PLC Stamp mini 2

Parts of the module that are not related to insulation are located below a metal shield. Information about the module are printed on a high-temperature label on top of this shield.



Figure 2 Image of the Module

8 Technical Data

8.1 Absolute Maximum Ratings

SYMBOL	PARAMETER	Min.	Max.	UNIT
VDD	Digital supply voltage	-0.3	3.46	V
VDIO	Digital input voltage	-0.3	3.63	V
TSTORE	Storage temperature	-40	150	°C
RAH	Relative air humidity (not condensing)	10	90	%

Table 1 Absolute Maximum Ratings

8.2 Operating Conditions

SYMBOL	PARAMETER	Min.	Typ.	Max.	UNIT
VDD	Digital supply voltage	3.13	3.3	3.46	V
IDD	Current for VDD	-	150 (average)	300	mA
VAC	Mains Voltage (AC)	85	110 / 230	250	V
VDC (1)	Mains Voltage (DC)	-	-	380	V
fAC (2)	Mains Frequency Tolerance (50Hz)	48.5	50	51.5	Hz
	Mains Frequency Tolerance (60Hz)	57.9	60	62.1	Hz
TCASE	Top of case temperature (industrial)	-40	-	85	°C
	Top of case temperature (commercial)	0	-	70	°C
I_GPIO	GPIO current	-	-	12	mA

Table 2 Operating Conditions

Notes:

1. DC Voltage is specified as the sum of all AC and DC parts of the line.
2. If you couple PLC Stamp Mini 2 to a DC Line make sure to tie the ZC_IN pin to low via a 10 kOhm resistor.

8.3 Safety

Isolation between L/N terminals and all other connections: 8 mm creepage / 6.5 mm clearance

Isolation test voltage: 4000 Vac

9 Firmware and MAC Addresses

These modules are pre-programmed with firmware and parameter information block (PIB). The PIB contains the MAC addresses of the module, prescaler values defining the output power as well as settings for automotive use of the QCA7000 / QCA7005 (SLAC). The MAC address uses a prefix (organizationally unique identifier) that is assigned to in-tech smart charging. The prescaler values that are set in the production process were defined by Qualcomm for the intended application / market (see order option Parameter Optimization). Automotive variants include settings to enable SLAC for either the EVSE or the PEV side.

10 Module Pinout

PIN	Direction	Name	Description
1	IN/OUT	GPIO_0	QCA7000 / QCA7005 GPIO 0
2	IN/OUT	GPIO_1	QCA7000 / QCA7005 GPIO 1
3	IN/OUT	GPIO_2	QCA7000 / QCA7005 GPIO 2
4	IN/OUT	GPIO_3	QCA7000 / QCA7005 GPIO 3
5	IN	RESET_L	Reset (low active)
6	IN/OUT	SERIAL_4	Serial_4 of QCA7000 / QCA7005
7	IN/OUT	SERIAL_3	Serial_3 of QCA7000 / QCA7005
8	IN/OUT	SERIAL_2	Serial_2 of QCA7000 / QCA7005
9	IN/OUT	SERIAL_1	Serial_1 of QCA7000 / QCA7005
10	IN/OUT	SERIAL_0	Serial_0 of QCA7000 / QCA7005
11	SUPPLY	GND	Ground connection
12	SUPPLY	VDD	Supply Voltage for the module
13	IN	N.C. / ZC_IN	do not connect (home automation variant), zero cross detection input (automotive variant)
14	-	-	not available
15	IN/OUT	N	Powerline communication
16	IN/OUT	L	Powerline communication
17	IN/OUT	L	Powerline communication
18*	SUPPLY	GND	Ground connection
19*	SUPPLY	GND	Ground connection
20*	SUPPLY	GND	Ground connection
21*	SUPPLY	GND	Ground connection
22*	SUPPLY	GND	Ground connection
23*	SUPPLY	GND	Ground connection
24*	SUPPLY	GND	Ground connection
25*	SUPPLY	GND	Ground connection

Table 3 Module Pinout

* not needed for electrical function, only for SMD assembly

10.1 GPIO

10.1.1 Power-on Configuration

The QCA7000 / QCA7005 comprises four GPIO pins which are read at boot time to get the desired configuration. Table 4 shows the configuration the QCA7000 / QCA7005 at boot time.

GPIO #	Function	Pull Up	Pull Down	Preload on Module
0	Boot Source	Flash	Host	-
1	Host Interface	-	SPI Slave	10 kOhm Pull Down
2	SPI Slave Mode	Burst	Legacy	-
3	None	-	-	-

Table 4 QCA7000 / QCA7005 Boot Strap Options

10.1.2 General Purpose I/O Functions

The GPIOs of the QCA7000 / QCA7005 have different functions after booting. They can either be used as input or output to display various states or trigger some actions. It is not possible to use these pins from your own application - only the QCA7000 / QCA7005 firmware can control these GPIOs.

The GPIOs are set up as specified in table 5.

GPIO #	Direction	Function
0	Output	PLC connection (1=connection established, 0=no connection)
1	Output	Pushbutton Simple Connect (toggling 1/0 with 1Hz: simple connect mode active, 0: not in simple connect mode)
2	Output	unused in default configuration
3	Input	Pushbutton Simple Connect (hold time: 0.5 to 3s), NMK randomize (hold time: 5 to 8s), Factory defaults (hold time: 10 to 15s)

Table 5 QCA7000 / QCA7005 GPIO Settings

Since the GPIO are also used as bootstrap pins special attention should be paid to the LED (figure 3) and switch (figure 4) connection according to the strap direction. Behaviour in table 5 states a '1' for a pressed button or a lit LED, the electrical state (high/low) depends on the direction of the bootstrap resistor.

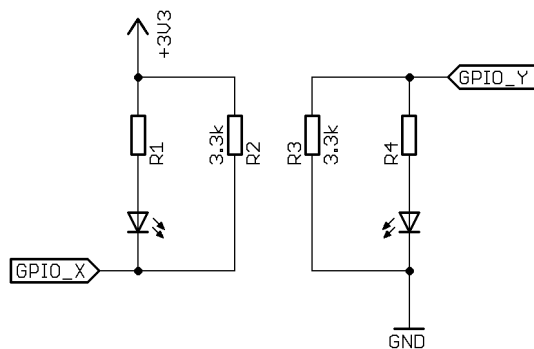

Figure 3 GPIO LED Bootstrap

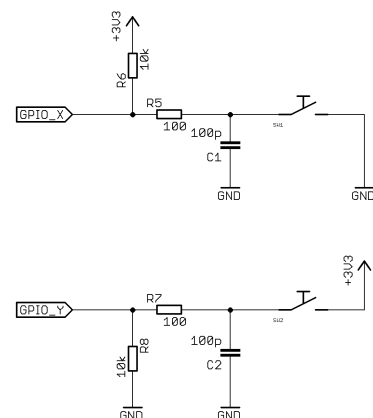

Figure 4 GPIO Switch Bootstrap

10.2 Serial Signals

The signals SERIAL_0 to SERIAL_4 represent the SPI or UART signals. Table 6 contains the UART and SPI function for each signal.

Signal Name	SPI function	UART function
SERIAL_0	Interrupt	
SERIAL_1	CLK	RTS
SERIAL_2	CS	CTS
SERIAL_3	MISO	TXD
SERIAL_4	MOSI	RXD

Table 6 QCA7000 / QCA7005 UART/SPI Signals

Please note that the selection between SPI and UART mode is effected using different QCA7000 / QCA7005 firmware and is therefore an order option.

10.2.1 UART

All module variants in UART mode use the settings in table 7. Pins RTS and CTS are not used.

Settings	Value
Baud Rate	115200
Data Bits	8
Parity	None
Stop Bits	1
Flow Control	None

Table 7 UART Settings

10.2.2 SPI

The QCA7000 / QCA7005 uses Motorola SPI mode 3: CPOL=1, CPHA=1.

SPI should be used in burst mode, meaning that the Chip Select signal is kept low during a complete SPI message.

The SPI CLK period should not be less than 83.3 ns resulting in a maximum clock frequency of 12 MHz.

11 Recommended Footprint

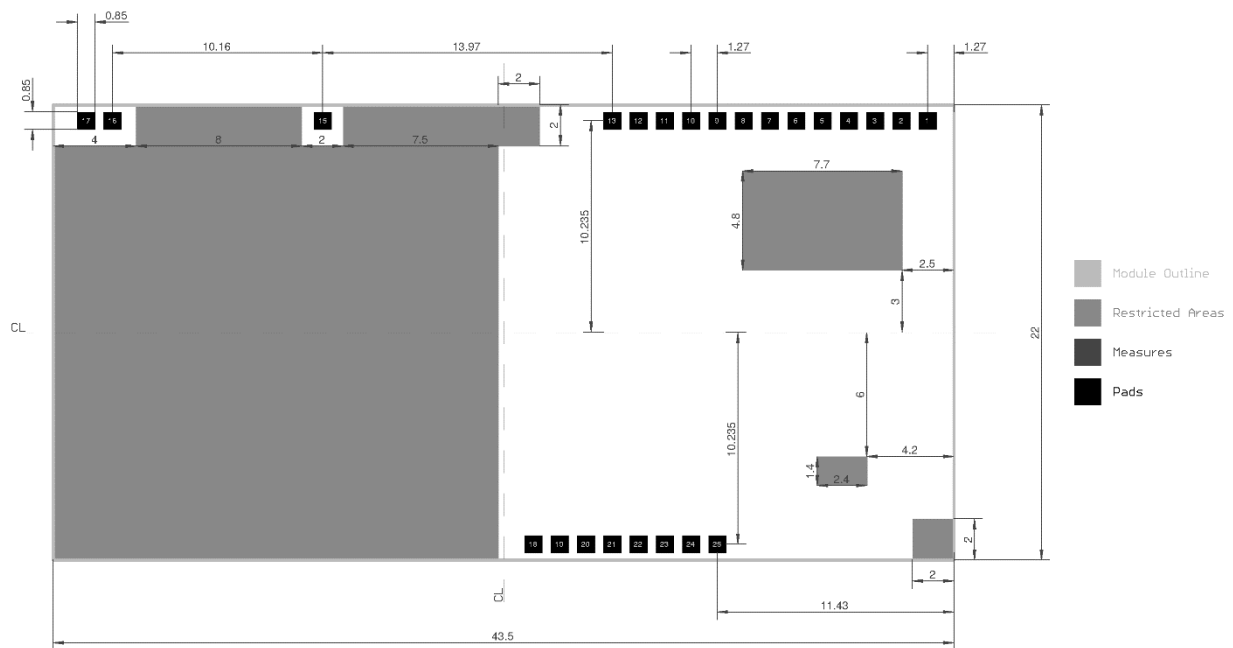

Figure 5 Recommended Footprint

Notes:

1. All dimensions are in mm.
2. Pads are all of the same size.
3. Distances between pads are equal if not otherwise specified in the drawing.
4. Pad 14 is not available for compatibility to the previous footprint of PLC Stamp mini
5. The drawing in [figure 5](#) shows the top view on the footprint (as if you look through the module).
6. Restricted areas should be kept free of copper on the base PCB.
7. The module outline shows the ideal measures - tolerance is not included.

12 Getting Started

The module does not need other parts for PLC connection. You need to connect it to:

1. 3.3 V supply
2. your processor (via SERIAL_0 through SERIAL_4)
3. to L and N of your mains circuit or to GND and CP for automotive uses (see order variants)

Refer to table 3 to see how the module needs to be connected.

The following two sections detail the difference between mains connected and automotive applications.

12.1 CE Class B / North American Variant

The PLC Transformer used for these variants has a turns ratio of 1:4:5 and the Zero Cross Detection circuit is present, which is necessary for Powerline communication over the mains. Let the zero cross detection (Pin 13) floating.

The GPIO pins, the reset pin and the ZC pin do not need to be connected.

12.2 Automotive EVSE / PEV



NOTICE

Automotive variants of PLC Stamp mini 2 are not designed to work on mains.

Connect pin 16 and 17 of the module to GND and use pin 15 for the powerline communication. Do not connect pin 15-17 to the AC line.

The GPIO pins, and the reset pin do not need to be connected.

The PLC Transformer has a turns ratio of 1:1:1.

These variants are not equipped with a Zero Cross Detection circuit. Some devices shall be capable to detect the zero cross of the AC line to support coexistence functionality. In this case refer to figure 6. Connect signals L and N of figure 6 to mains neutral and line and ZC_IN to pin 13 of the module. Usually the EVSE should have the zero cross detection while PEV naturally do not need it.

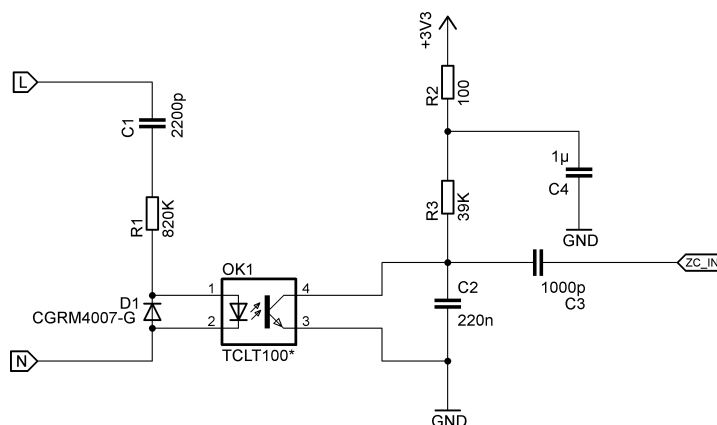

Figure 6 Schematic Zero-cross Detection

13 Processing

- Process the modules according to IPC/JEDEC J-STD-020 and J-STD-033 guidelines.
- Limit repeated reflow processes to maximum 2.

14 Module Marking

Each Module is marked with a label containing the following data:

1. Order Code
2. QCA7000 / QCA7005 MAC Address (printed with a separating colon every two digits, the DataMatrix code contains the digits without separator)
3. Serial Number
4. Production Date Code: WWYY
5. Device Security Key
6. 2D DataMatrix code containing the above information as a list of space separated values

Additionally each label contains:

1. in-tech Banner
2. Pin 1 Marking

An example is shown in figure 7.



Figure 7 Example Label for PLC Stamp Mini 2

15 Order Information

Order Code	Chip	Temperature Range / °C	Serial Interface	Application	PLC Transformer	Zero Cross Detection	Packaging	Availability
Version 004								
I2PLCAMN-ISC-004-T	QCA7000	-40 - 85	SPI	CE Class B	I2PLCTR-1	on module	Tray, 20pcs	standard
I2PLCAMN-ISC-004-R	QCA7000	-40 - 85	SPI	CE Class B	I2PLCTR-1	on module	Tape and Reel, 240pcs	standard
I2PLCAMN-ISN-004-T	QCA7000	-40 - 85	SPI	North America	I2PLCTR-1	on module	Tray, 20pcs	standard
I2PLCAMN-ISN-004-R	QCA7000	-40 - 85	SPI	North America	I2PLCTR-1	on module	Tape and Reel, 240pcs	standard
I2PLCAMN-ISE-004-T	QCA7000	-40 - 85	SPI	Automotive EVSE	I2PLCTR-2	external	Tray, 20pcs	standard
I2PLCAMN-ISE-004-R	QCA7000	-40 - 85	SPI	Automotive EVSE	I2PLCTR-2	external	Tape and Reel, 240pcs	standard
I2PLCAMN-ISP-004-T	QCA7000	-40 - 85	SPI	Automotive PEV	I2PLCTR-2	external	Tray, 20pcs	standard
I2PLCAMN-ISP-004-R	QCA7000	-40 - 85	SPI	Automotive PEV	I2PLCTR-2	external	Tape and Reel, 240pcs	standard
I2PLCAMN-IUC-004-T	QCA7000	-40 - 85	UART	CE Class B	I2PLCTR-1	on module	Tray, 20pcs	standard
I2PLCAMN-IUC-004-R	QCA7000	-40 - 85	UART	CE Class B	I2PLCTR-1	on module	Tape and Reel, 240pcs	standard
I2PLCAMN-IUN-004-T	QCA7000	-40 - 85	UART	North America	I2PLCTR-1	on module	Tray, 20pcs	standard
I2PLCAMN-IUN-004-R	QCA7000	-40 - 85	UART	North America	I2PLCTR-1	on module	Tape and Reel, 240pcs	standard
I2PLCAMN-IUE-004-T	QCA7000	-40 - 85	UART	Automotive EVSE	I2PLCTR-2	external	Tray, 20pcs	standard

Order Code	Chip	Temperature Range / °C	Serial Interface	Application	PLC Transformer	Zero Cross Detection	Packaging	Availability
I2PLCAMN-IUE-004-R	QCA7000	-40 - 85	UART	Automotive EVSE	I2PLCTR-2	external	Tape and Reel, 240pcs	standard
I2PLCAMN-IUP-004-T	QCA7000	-40 - 85	UART	Automotive PEV	I2PLCTR-2	external	Tray, 20pcs	standard
I2PLCAMN-IUP-004-R	QCA7000	-40 - 85	UART	Automotive PEV	I2PLCTR-2	external	Tape and Reel, 240pcs	standard
I2PLCAMN-CSC-004-T	QCA7000	0 - 70	SPI	CE Class B	I2PLCTR-1	on module	Tray, 20pcs	on request
I2PLCAMN-CSC-004-R	QCA7000	0 - 70	SPI	CE Class B	I2PLCTR-1	on module	Tape and Reel, 240pcs	on request
I2PLCAMN-CSN-004-T	QCA7000	0 - 70	SPI	North America	I2PLCTR-1	on module	Tray, 20pcs	on request
I2PLCAMN-CSN-004-R	QCA7000	0 - 70	SPI	North America	I2PLCTR-1	on module	Tape and Reel, 240pcs	on request
I2PLCAMN-CSE-004-T	QCA7000	0 - 70	SPI	Automotive EVSE	I2PLCTR-2	external	Tray, 20pcs	on request
I2PLCAMN-CSE-004-R	QCA7000	0 - 70	SPI	Automotive EVSE	I2PLCTR-2	external	Tape and Reel, 240pcs	on request
I2PLCAMN-CSP-004-T	QCA7000	0 - 70	SPI	Automotive PEV	I2PLCTR-2	external	Tray, 20pcs	on request
I2PLCAMN-CSP-004-R	QCA7000	0 - 70	SPI	Automotive PEV	I2PLCTR-2	external	Tape and Reel, 240pcs	on request
I2PLCAMN-CUC-004-T	QCA7000	0 - 70	UART	CE Class B	I2PLCTR-1	on module	Tray, 20pcs	on request
I2PLCAMN-CUC-004-R	QCA7000	0 - 70	UART	CE Class B	I2PLCTR-1	on module	Tape and Reel, 240pcs	on request
I2PLCAMN-CUN-004-T	QCA7000	0 - 70	UART	North America	I2PLCTR-1	on module	Tray, 20pcs	on request
I2PLCAMN-CUN-004-R	QCA7000	0 - 70	UART	North America	I2PLCTR-1	on module	Tape and Reel, 240pcs	on request

Order Code	Chip	Temperature Range / °C	Serial Interface	Application	PLC Transformer	Zero Cross Detection	Packaging	Availability
I2PLCAMN-CUE-004-T	QCA7000	0 - 70	UART	Automotive EVSE	I2PLCTR-2	external	Tray, 20pcs	on request
I2PLCAMN-CUE-004-R	QCA7000	0 - 70	UART	Automotive EVSE	I2PLCTR-2	external	Tape and Reel, 240pcs	on request
I2PLCAMN-CUP-004-T	QCA7000	0 - 70	UART	Automotive PEV	I2PLCTR-2	external	Tray, 20pcs	on request
I2PLCAMN-CUP-004-R	QCA7000	0 - 70	UART	Automotive PEV	I2PLCTR-2	external	Tape and Reel, 240pcs	on request
I2PLCBMN-ISC-004-T	QCA7005	-40 - 85	SPI	CE Class B	I2PLCTR-1	on module	Tray, 20pcs	on request
I2PLCBMN-ISC-004-R	QCA7005	-40 - 85	SPI	CE Class B	I2PLCTR-1	on module	Tape and Reel, 240pcs	on request
I2PLCBMN-ISN-004-T	QCA7005	-40 - 85	SPI	North America	I2PLCTR-1	on module	Tray, 20pcs	on request
I2PLCBMN-ISN-004-R	QCA7005	-40 - 85	SPI	North America	I2PLCTR-1	on module	Tape and Reel, 240pcs	on request
I2PLCBMN-ISE-004-T	QCA7005	-40 - 85	SPI	Automotive EVSE	I2PLCTR-2	external	Tray, 20pcs	on request
I2PLCBMN-ISE-004-R	QCA7005	-40 - 85	SPI	Automotive EVSE	I2PLCTR-2	external	Tape and Reel, 240pcs	on request
I2PLCBMN-ISP-004-T	QCA7005	-40 - 85	SPI	Automotive PEV	I2PLCTR-2	external	Tray, 20pcs	on request
I2PLCBMN-ISP-004-R	QCA7005	-40 - 85	SPI	Automotive PEV	I2PLCTR-2	external	Tape and Reel, 240pcs	on request
I2PLCBMN-IUC-004-T	QCA7005	-40 - 85	UART	CE Class B	I2PLCTR-1	on module	Tray, 20pcs	on request
I2PLCBMN-IUC-004-R	QCA7005	-40 - 85	UART	CE Class B	I2PLCTR-1	on module	Tape and Reel, 240pcs	on request
I2PLCBMN-IUN-004-T	QCA7005	-40 - 85	UART	North America	I2PLCTR-1	on module	Tray, 20pcs	on request

Order Code	Chip	Temperature Range / °C	Serial Interface	Application	PLC Transformer	Zero Cross Detection	Packaging	Availability
I2PLCBMN-IUN-004-R	QCA7005	-40 - 85	UART	North America	I2PLCTR-1	on module	Tape and Reel, 240pcs	on request
I2PLCBMN-IUE-004-T	QCA7005	-40 - 85	UART	Automotive EVSE	I2PLCTR-2	external	Tray, 20pcs	on request
I2PLCBMN-IUE-004-R	QCA7005	-40 - 85	UART	Automotive EVSE	I2PLCTR-2	external	Tape and Reel, 240pcs	on request
I2PLCBMN-IUP-004-T	QCA7005	-40 - 85	UART	Automotive PEV	I2PLCTR-2	external	Tray, 20pcs	on request
I2PLCBMN-IUP-004-R	QCA7005	-40 - 85	UART	Automotive PEV	I2PLCTR-2	external	Tape and Reel, 240pcs	on request
Version 003 not recommended for new designs (NRND)								
I2PLCAMN-ISC-003-T	QCA7000	-40 - 85	SPI	CE Class B	I2PLCTR-1	on module	Tray, 20pcs	NRND
I2PLCAMN-ISC-003-R	QCA7000	-40 - 85	SPI	CE Class B	I2PLCTR-1	on module	Tape and Reel, 240pcs	NRND
I2PLCAMN-ISN-003-T	QCA7000	-40 - 85	SPI	North America	I2PLCTR-1	on module	Tray, 20pcs	NRND
I2PLCAMN-ISN-003-R	QCA7000	-40 - 85	SPI	North America	I2PLCTR-1	on module	Tape and Reel, 240pcs	NRND
I2PLCAMN-IUC-003-T	QCA7000	-40 - 85	UART	CE Class B	I2PLCTR-1	on module	Tray, 20pcs	NRND
I2PLCAMN-IUC-003-R	QCA7000	-40 - 85	UART	CE Class B	I2PLCTR-1	on module	Tape and Reel, 240pcs	NRND
I2PLCAMN-IUN-003-T	QCA7000	-40 - 85	UART	North America	I2PLCTR-1	on module	Tray, 20pcs	NRND
I2PLCAMN-IUN-003-R	QCA7000	-40 - 85	UART	North America	I2PLCTR-1	on module	Tape and Reel, 240pcs	NRND
I2PLCAMN-CSC-003-T	QCA7000	0 - 70	SPI	CE Class B	I2PLCTR-1	on module	Tray, 20pcs	NRND

Order Code	Chip	Temperature Range / °C	Serial Interface	Application	PLC Transformer	Zero Cross Detection	Packaging	Availability
I2PLCAMN-CSC-003-R	QCA7000	0 - 70	SPI	CE Class B	I2PLCTR-1	on module	Tape and Reel, 240pcs	NRND
I2PLCAMN-CSN-003-T	QCA7000	0 - 70	SPI	North America	I2PLCTR-1	on module	Tray, 20pcs	NRND
I2PLCAMN-CSN-003-R	QCA7000	0 - 70	SPI	North America	I2PLCTR-1	on module	Tape and Reel, 240pcs	NRND
I2PLCAMN-CUC-003-T	QCA7000	0 - 70	UART	CE Class B	I2PLCTR-1	on module	Tray, 20pcs	NRND
I2PLCAMN-CUC-003-R	QCA7000	0 - 70	UART	CE Class B	I2PLCTR-1	on module	Tape and Reel, 240pcs	NRND
I2PLCAMN-CUN-003-T	QCA7000	0 - 70	UART	North America	I2PLCTR-1	on module	Tray, 20pcs	NRND
I2PLCAMN-CUN-003-R	QCA7000	0 - 70	UART	North America	I2PLCTR-1	on module	Tape and Reel, 240pcs	NRND
I2PLCBMN-ISC-003-T	QCA7005	-40 - 85	SPI	CE Class B	I2PLCTR-1	on module	Tray, 20pcs	NRND
I2PLCBMN-ISC-003-R	QCA7005	-40 - 85	SPI	CE Class B	I2PLCTR-1	on module	Tape and Reel, 240pcs	NRND
I2PLCBMN-ISN-003-T	QCA7005	-40 - 85	SPI	North America	I2PLCTR-1	on module	Tray, 20pcs	NRND
I2PLCBMN-ISN-003-R	QCA7005	-40 - 85	SPI	North America	I2PLCTR-1	on module	Tape and Reel, 240pcs	NRND
I2PLCBMN-IUC-003-T	QCA7005	-40 - 85	UART	CE Class B	I2PLCTR-1	on module	Tray, 20pcs	NRND
I2PLCBMN-IUC-003-R	QCA7005	-40 - 85	UART	CE Class B	I2PLCTR-1	on module	Tape and Reel, 240pcs	NRND
I2PLCBMN-IUN-003-T	QCA7005	-40 - 85	UART	North America	I2PLCTR-1	on module	Tray, 20pcs	NRND
I2PLCBMN-IUN-003-R	QCA7005	-40 - 85	UART	North America	I2PLCTR-1	on module	Tape and Reel, 240pcs	NRND

Order Code	Chip	Temperature Range / °C	Serial Interface	Application	PLC Transformer	Zero Cross Detection	Packaging	Availability
Version 002 not recommended for new designs (NRND)								
I2PLCAMN-ISC-002-T	QCA7000	-40 - 85	SPI	CE Class B	I2PLCTR-1	on module	Tray, 20pcs	NRND
I2PLCAMN-ISC-002-R	QCA7000	-40 - 85	SPI	CE Class B	I2PLCTR-1	on module	Tape and Reel, 240pcs	NRND
I2PLCAMN-ISN-002-T	QCA7000	-40 - 85	SPI	North America	I2PLCTR-1	on module	Tray, 20pcs	NRND
I2PLCAMN-ISN-002-R	QCA7000	-40 - 85	SPI	North America	I2PLCTR-1	on module	Tape and Reel, 240pcs	NRND
I2PLCAMN-IUC-002-T	QCA7000	-40 - 85	UART	CE Class B	I2PLCTR-1	on module	Tray, 20pcs	NRND
I2PLCAMN-IUC-002-R	QCA7000	-40 - 85	UART	CE Class B	I2PLCTR-1	on module	Tape and Reel, 240pcs	NRND
I2PLCAMN-IUN-002-T	QCA7000	-40 - 85	UART	North America	I2PLCTR-1	on module	Tray, 20pcs	NRND
I2PLCAMN-IUN-002-R	QCA7000	-40 - 85	UART	North America	I2PLCTR-1	on module	Tape and Reel, 240pcs	NRND
I2PLCAMN-CSC-002-T	QCA7000	0 - 70	SPI	CE Class B	I2PLCTR-1	on module	Tray, 20pcs	NRND
I2PLCAMN-CSC-002-R	QCA7000	0 - 70	SPI	CE Class B	I2PLCTR-1	on module	Tape and Reel, 240pcs	NRND
I2PLCAMN-CSN-002-T	QCA7000	0 - 70	SPI	North America	I2PLCTR-1	on module	Tray, 20pcs	NRND
I2PLCAMN-CSN-002-R	QCA7000	0 - 70	SPI	North America	I2PLCTR-1	on module	Tape and Reel, 240pcs	NRND
I2PLCAMN-CUC-002-T	QCA7000	0 - 70	UART	CE Class B	I2PLCTR-1	on module	Tray, 20pcs	NRND
I2PLCAMN-CUC-002-R	QCA7000	0 - 70	UART	CE Class B	I2PLCTR-1	on module	Tape and Reel, 240pcs	NRND
I2PLCAMN-CUN-002-T	QCA7000	0 - 70	UART	North America	I2PLCTR-1	on module	Tray, 20pcs	NRND

Order Code	Chip	Temperature Range / °C	Serial Interface	Application	PLC Transformer	Zero Cross Detection	Packaging	Availability
I2PLCAMN-CUN-002-R	QCA7000	0 - 70	UART	North America	I2PLCTR-1	on module	Tape and Reel, 240pcs	NRND
I2PLCBMN-ISC-002-T	QCA7005	-40 - 85	SPI	CE Class B	I2PLCTR-1	on module	Tray, 20pcs	NRND
I2PLCBMN-ISC-002-R	QCA7005	-40 - 85	SPI	CE Class B	I2PLCTR-1	on module	Tape and Reel, 240pcs	NRND
I2PLCBMN-ISN-002-T	QCA7005	-40 - 85	SPI	North America	I2PLCTR-1	on module	Tray, 20pcs	NRND
I2PLCBMN-ISN-002-R	QCA7005	-40 - 85	SPI	North America	I2PLCTR-1	on module	Tape and Reel, 240pcs	NRND
I2PLCBMN-IUC-002-T	QCA7005	-40 - 85	UART	CE Class B	I2PLCTR-1	on module	Tray, 20pcs	NRND
I2PLCBMN-IUC-002-R	QCA7005	-40 - 85	UART	CE Class B	I2PLCTR-1	on module	Tape and Reel, 240pcs	NRND
I2PLCBMN-IUN-002-T	QCA7005	-40 - 85	UART	North America	I2PLCTR-1	on module	Tray, 20pcs	NRND
I2PLCBMN-IUN-002-R	QCA7005	-40 - 85	UART	North America	I2PLCTR-1	on module	Tape and Reel, 240pcs	NRND

Table 8 PLC Stamp mini 2 Order Codes

Product Family Code	Chip		Temperature Range	Serial Interface	Parameter Optimization	Version	Packaging
I2PLC	A: QCA7000	MN-	I: Industrial (-40 - 85 °C)	S: SPI	C: CE Class B	-002*	-T: Tray, 20pcs
	B: QCA7005		C: Commercial (0 - 70 °C) - only for QCA7000	U: UART	N: North America	-003*	-R: Tape and Reel, 240pcs
					E: Automotive EVSE	-004	
					P: Automotive PEV		

Table 9 PLC Stamp mini 2 Order Code Compilation

Order Code Version	QCA Firmware Version
002*	1.1.3
003*	1.2.3
004	1.2.5

Table 10 PLC Stamp mini 2 Order Code Version to QCA Firmware Version Mapping

*:not recommended for new designs

16 Package Materials Information

16.1 Tape and Reel

Tape and Reel according to EIA-481

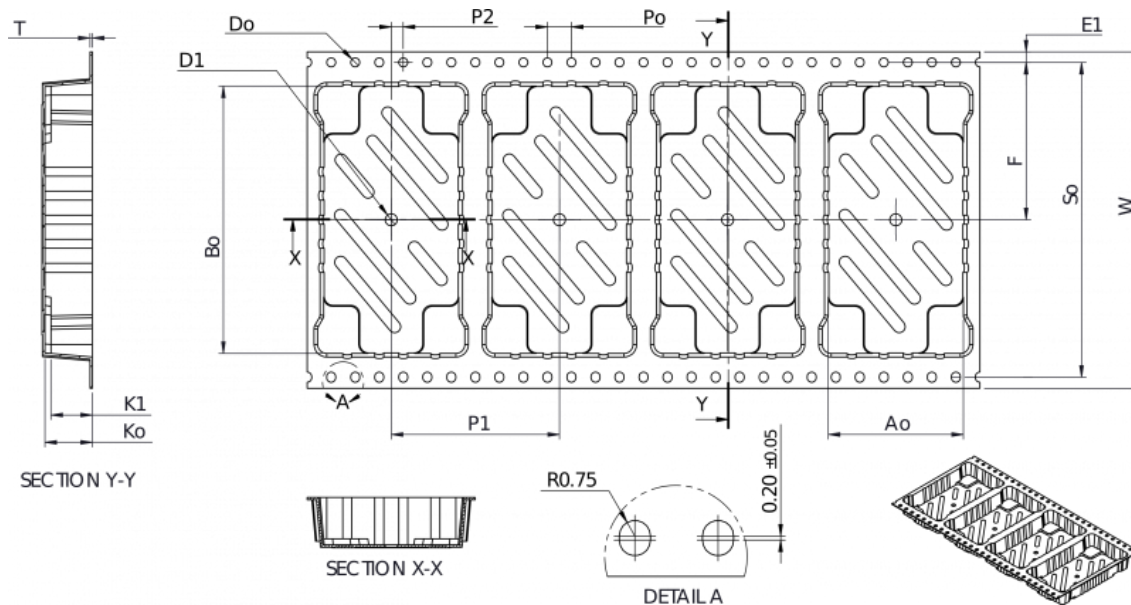

Figure 8 Tape and Reel according to EIA-481

Ao	$22,5 \pm 0,2$
Bo	$44,5 \pm 0,2$
D1	$\text{Ø}2,0 \text{ MIN}$
Do	$\text{Ø}1,5 + 0,1$
E1	$1,75 \pm 0,10$
F (III)	$26,20 \pm 0,15$
Ko	$7,9 \pm 0,2$
K1	$6,9 \pm 0,2$
P1	$28,00 \pm 0,15$
P2 (I)	$2,00 \pm 0,15$
Po (II)	$4,00 \pm 0,15$
So	$52,40 \pm 0,15$
T	$0,40 \pm 0,04$
W	$56,0 \pm 0,3$

All dimensions in millimeters unless otherwise stated.

Material: Polystyrene

(I)	Measured from centreline of sprocket hole to centreline of pocket
(II)	Cumulative tolerance of 10 sprocket holes is $\pm 0,20$
(III)	Measured from centreline of sprocket hole to centreline of sprocket

Reel Dimensions

Reel inner Diameter	4"
Reel outer Diameter	13"
Reel inner Width (Measured at hub)	56.4 + 2.0
Reel outer Width (Measured at hub)	62.4 MAX
Parts/Carrier Tape-Reel	240
Tape leader empty cavities	7..12
Tape trailer empty cavities	7..12

16.1.1 Orientation of the Module

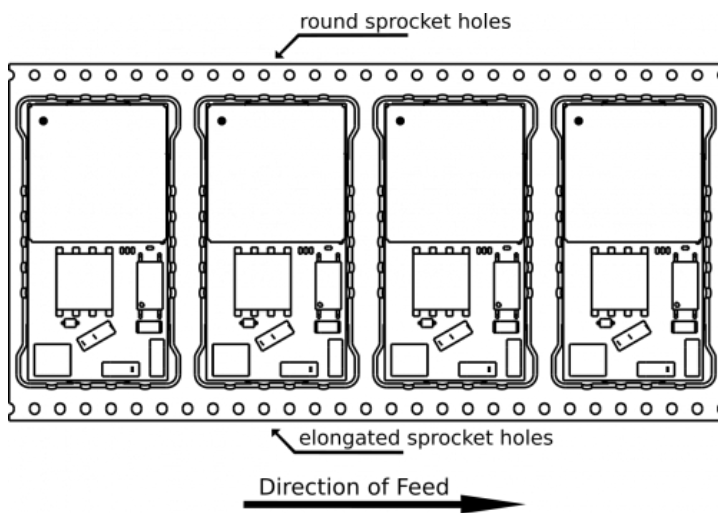

Figure 9 Orientation of the Module

16.2 Tape and Reel Cardboard Box Dimensions

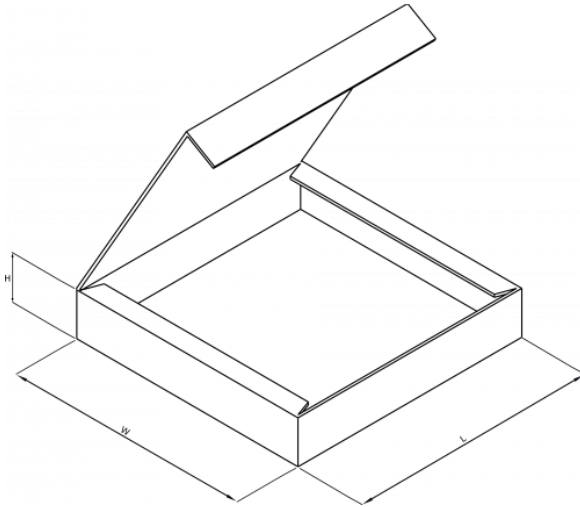

Figure 10 Tape and Reel Cardboard Box Dimensions

H	65 mm
W	340 mm
L	340 mm

17 Contact

in-tech smart charging GmbH

Friedrich-List-Platz 2

04103 Leipzig

Germany

Website: <https://in-tech-smartcharging.com>